

**Jury Base Seating
Forum Chair**



Theatre Solutions, Inc.

Jury Base Seating Forum Chair Specifications



Shell: The inner shell shall be an electronically glued plywood construction of varying thicknesses. The minimum thickness shall be 1/2" - 7plys with a maximum thickness of 11/16" - 11 plys. The shell shall be contoured to an ergonomically correct configuration. The shell shall be fitted with threaded "t"-nuts and 11 gauge steel plates for the attachment of the swivel mechanism and armrests. The polyurethane foam padding shall be glued to the shell and conform to CA TB117. Foam padding shall not be less than 2" thick at any location on the seat and 1 1/2" thick on any location on the back. The upholstery shall be a sewn cover that is stapled in place. The bottom of the seat shall be covered with a black cambric cloth.



Armrest: The arm shall be black self-skinned urethane foam molded over an inner steel structure. The arm shall be attached to the shell with an 11 gauge steel bracket assembly and machine screws.

Mechanism: The tilt mechanism shall be a steel weldment assembly which includes a mounting plate with (4) mounting holes for attachment to the shell and a 17-4 tapered receptacle for mounting to the swivel/return cylinder post. The tilt mechanism shall include a tilt tension adjustment knob.

The optional non-tilt mechanism shall include a steel mounting plate with (4) mounting holes for attachment to the shell and a 17-4 tapered receptacle for mounting to the swivel/return cylinder post.



Base: The base assembly shall consist of a T-6 cast aluminum jury base which is finished with black powder coating. The base is equipped with (4) countersunk mounting holes for flush floor mounting screws. The base plate has a raised center section with a tapered receptacle or the swivel return cylinder. The swivel return cylinder shall allow for 360 degree rotation and automatically return the seat to its original orientation. The cylinder shall be covered with a two-piece molded shroud.

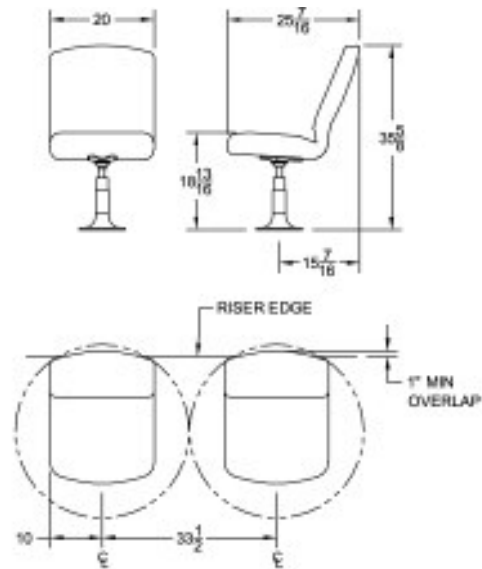

Forum Jury Base Chair
Non-Tilt, Without Arms

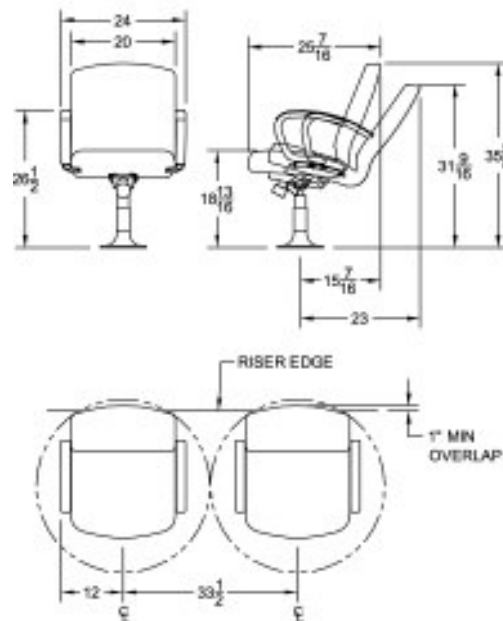

Forum Jury Base Chair
Tilt, With Arms



Theatre Solutions, Inc.

121 Park Avenue, Quakertown, PA 18951
Tel 215.538.8033 Fax 215.538.8974
www.theatresolutions.net
info@theatresolutions.net